

## Astrix-PD

### 18W / 25W Acoustic Rated Pendant

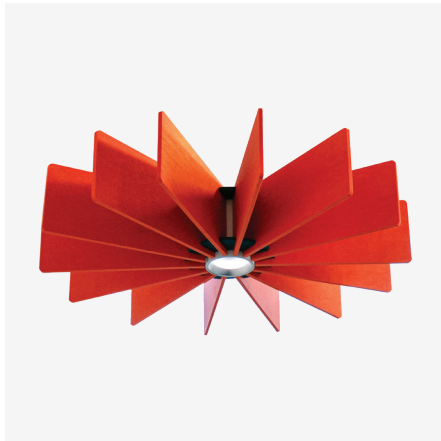

Luminaire Finishes

White (WH)  Black (BK)

Interchangeable Baffle Finishes

White (WH)  Black (BK)  Matt (MT)

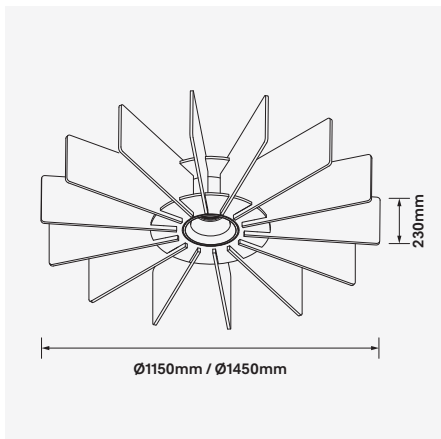

#### Accessories

##### Wire Suspension Kit (WSUS)

Part No: SUSKIT-3M-SIL  
Colour: Silver  
Length: 3m Adjustable



##### Wire Suspension Kit (WSUS)

Part No: SUSKIT-3M-BLK  
Colour: Black  
Length: 3m Adjustable



##### Rod Suspension Kit (RSUS)

Part No: ROD-SUS-KIT-1M-WHT  
Colour: White  
Length: 1m Adjustable



##### Rod Suspension Kit (RSUS)

Part No: ROD-SUS-KIT-1M-BLK  
Colour: Black  
Length: 1m Adjustable



**WATTAGE 18W / 25W** | **IP 54** | **UGR <19** | **Bluetooth** | **Z** | **BAKT** | **CE** | **WARRANTY 5YR**  
**Suspended** | **Ø1150 / 1450** | **CRI (Ra) >90** | **30° / 60°** | **Recyclable** | **Sound Absorbing**  
**Fire Rated Class A**

The Astrix is an acoustic, eco-friendly pendant with a unique design. It's acoustic panels are made from 60% recycled materials and provide the ability to soften and reduce reverberation through absorption of certain frequencies from the mid to high ranges. Available in two standard sizes and over 50 colours, the Astrix can be customised to suit the interiors of any project. The versatile fitting can also be used as a standalone piece or together as a cluster.

The Astrix is manufactured from 12mm thick panels of 100% Polyester Fibres (including 60% recyclable materials), which is safe, sustainable, non-toxic, non-irritant, and non-allergic. Astrix comes complete with a 5 year warranty.

- Luminaire wattage: 18W, 25W (System 21W, 28W)
- Luminous flux: 2000-2500Lm, 2700-3300Lm<sup>2</sup>
- Luminaire efficacy: 83Lm/W, 90Lm/W<sup>1</sup>
- Correlated colour temperature: 3000K, 4000K
- Colour rendering index: >90
- Mac-Adams x Ellipse: 3-SDCM
- LED brand: Citizen COB LED
- Glare control: UGR<19
- Symmetrical distribution: 30°, 60°
- Dimensions: Ø1150mm x H230mm; Ø1450mm x H230mm
- Ingress protection rating: IP54 (Front)
- Luminaire finish: White, Black
- Baffle options: White, Black, Matt
- PET: 12mm (50 Colours)<sup>5</sup>
- Mounting: 3m adjustable wire suspensions standard
- Longevity: >50,000Hrs L80 B10
- Driver: Tridonic non-dimmable LED driver as standard
- Dimming: DALI-2, BLE (basicDIM Wireless / casambi) on request<sup>4</sup>
- Weight: 5kgs Ø1150mm, 5.45kgs Ø1450mm
- Warranty: 5 years<sup>6</sup>

Model	LED Output <sup>2</sup>	Luminous Flux <sup>2</sup>	LED Wattage	System Wattage	CCT	CRI <sup>3</sup>	Distribution
ASTRIX-PDX-18W-3K-30	2800Lm	2300Lm	18W	21W	3000K	>90	30°
ASTRIX-PDX-18W-4K-30	3000Lm	2500Lm	18W	21W	4000K	>90	30°
ASTRIX-PDX-18W-3K-60	2800Lm	2000Lm	18W	21W	3000K	>90	60°
ASTRIX-PDX-18W-4K-60	3000Lm	2200Lm	18W	21W	4000K	>90	60°
ASTRIX-PDX-25W-3K-30	3800Lm	3100Lm	25W	28W	3000K	>90	30°
ASTRIX-PDX-25W-4K-30	4000Lm	3300Lm	25W	28W	4000K	>90	30°
ASTRIX-PDX-25W-3K-60	3800Lm	2700Lm	25W	28W	3000K	>90	60°
ASTRIX-PDX-25W-4K-60	4000Lm	2900Lm	25W	28W	4000K	>90	60°

For Non-dimming add suffix ND  
For DALI-2 dimming add suffix D  
For BLUETOOTH dimming add suffix BT

Replace X  
Replace X with 1150 for Ø1150mm  
Replace X with 1450 for Ø1450mm

Example product order code configuration: ASTRIX-PD1150-18W-3K-60-ND-(WH/MT/21)

Model	Diameter	Wattage	CCT	Distribution	Driver	Luminaire Finish / Baffle Finish / PET Colour						
ASTRIX-PD	+	1150	+	18W	+	3K	+	60	+	D	+	WH / MT / 21

#### Light Distribution

ASTRIX-WS-25W-3K-60

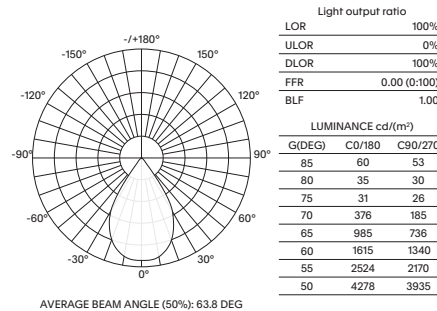

Utilisation Factors

Room Reflectance	Room Index											
Ceiling Walls Floor	0.80	1.00	1.25	1.50	2.00	2.50	3.00	4.00	5.00			
	70	50	20	89	93	98	101	104	105	107	110	111

#### Cone Diagram

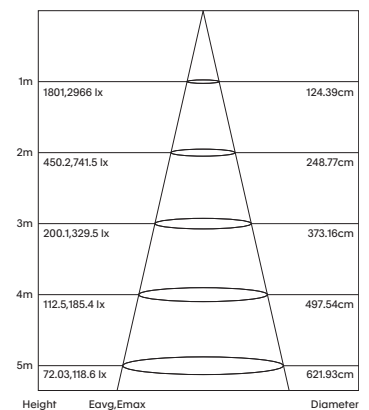



















































1 Luminaire efficacy based on CCT 3000K; CCT variation will alter efficacy  
2 +/- 10% stated initial LED and luminous flux tolerance  
3 Colour Rendering Index: >90 Standard (Citizen COB Series)  
4 Additional charges apply for non-standard colour/s and dimming options  
5 Despite every effort to provide an accurate colour image, actual colours may differ slightly due to different device screen settings and print type and media. It is advised that an actual colour swatch is requested prior to ordering  
6 Five year manufacturer's warranty covering product defects and performance deficiencies

## Astrix-PD

### 18W / 25W Acoustic Rated Pendant

Acoustic PET 9-12mm<sup>5</sup>

	Snow White 01		Creamy White 02		Sandy Beach 03
	Toffee Tart 04		Desert Oak 05		Earthy Cane 06
	Grey Cliff 07		Animal Kingdom 08		Phantom Hue 09
	Grey Water 10		Mercury 11		Cliff Tops 12
	Mineral Salt 13		Perfect Storm 14		Moonlight Grey 15
	Silver Steed 16		Eagle Feather 17		Black Sesame 18
	Black Ink 19		Turkish Delight 20		Saffron 21
	Rum Orange 22		Burnt Orange 23		Exotic Red 24
	Calypso Berry 25		Ruby 26		Renegade 27
	Firewood 28		Crossfire 29		Green Lemon 30
	Apple Green 31		Leap Frog 32		Irish Stone 33
	Pine Ridge 34		Irish Rogue 35		Magic Forest 36
	Lime Yellow 37		Olive Fizz 38		Lady Lime 39
	Spiced Butternut 40		Ocean Tide 41		South Pacific 42
	Aquamarine Sea 43		Fiji Water 44		Tempted Teal 45
	Sky Blue 46		Harbour View 47		Sea Blue 48
	Ocean Deep 49		Navy Blue 50		