

TR-SM26

48VDC Surface / Suspended Track System



Track Finish

Black (BK)

Surface / Suspended Track

Product No: TR-SM26
Colour: Black
Size: W26mm x H54mm
Weight: 1.2kgs/m

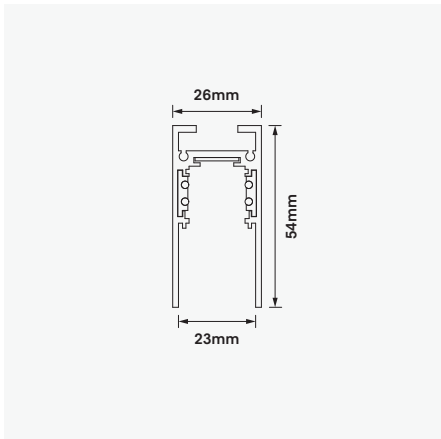

The 48VDC low voltage track system is synonymous with electrical safety, permitting greater flexibility and ease of use including installation. The luminaire can be installed and moved to any position without the need for turning off the power to the track. This is due to its low voltage input of 48VDC. No tools are required, the luminaires simply snap-lock into position, remaining in place until you want to remove or re-position the luminaire.

The elegant and minimalist design permits a range of micro luminaires ranging from spots, pendants and linear sources with many features. The system features simple on/off operation with additional dimming options to suit a number of protocols such as DALI or Bluetooth dimming. The system is designed to suit applications from residential through to retail and commercial. The 48VDC Track system is covered by a 5 year warranty.

- Mounting: Surface (standard); Suspended optional
- Construction: Extruded 6063T grade aluminium mounting profile
- Finish options: Matt Black
- Accessories: End caps & joiners configuration dependant
- Length (max.) 3000mm x Width 26mm x Height 54mm
- Ingress Protection Rating: IP20
- Specifically designed for 48VDC Spots,
- Linear and Pendants
- Compatible with on/off operation, DALI and BLE dimming protocols
- Weight: 1.2kgs/m (excluding driver & accessories)
- Warranty: 5 year!

Power Feed Unit

Product No: TR-26-PF-1M
Colour: Black
Size: W16mm x H17mm x L130mm
Weight: 9g

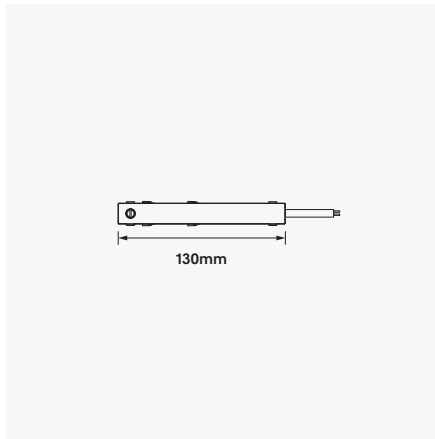

Power Straight Joiner

Product No: TR-26-PJ
Colour: Black
Size: W16mm x H17mm x L124mm
Weight: 105g

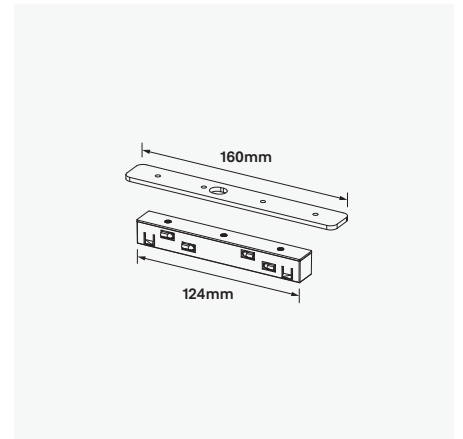

Power Flexible Joiner

Product No: TR-26-FJ
Colour: Black
Size: W16mm x H17mm x L130mm
Weight: 53g

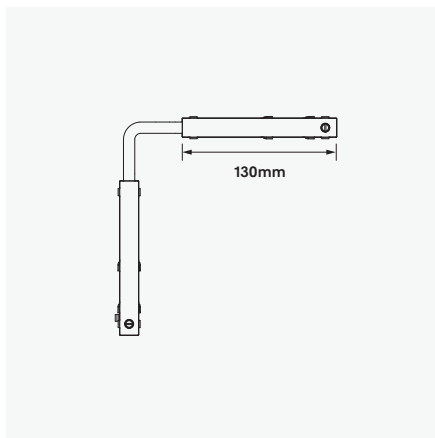

Bluetooth Wireless Module

Product No: TR-BLE-DALIGATE
Colour: Black
Size: W17mm x H54mm x L143mm
Weight: 62g

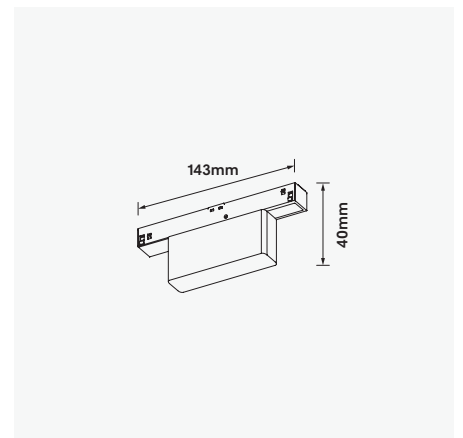

TR-SM26

48VDC Surface / Suspended Track System

Surface / Suspended Corner-V

Product No: TR-SM26-CNR-V
Colour: Black
Size: L100mm x 100mm (W26mm x H54mm)
Weight: 310g

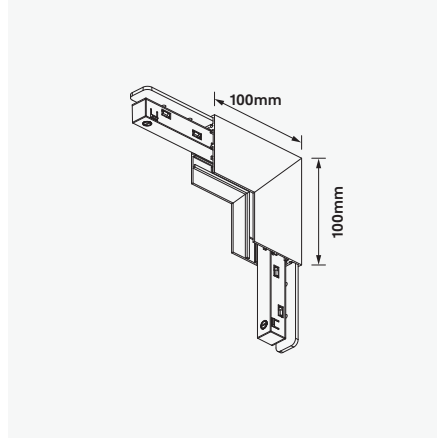

Surface / Suspended Corner-H

Product No: TR-SM26-CNR-H
Colour: Black
Size: L100mm x 100mm (W26mm x H54mm)
Weight: 310g

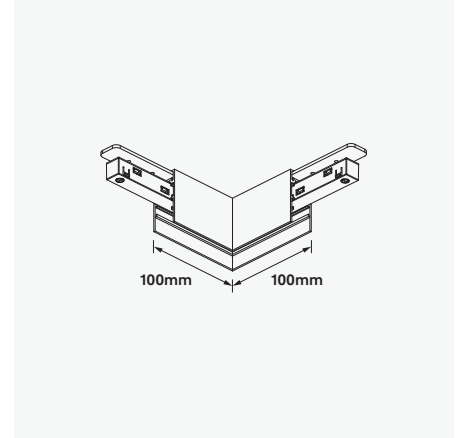

Surface / Suspended Corner-E

Product No: TR-SM26-CNR-E
Colour: Black
Size: L100mm x 100mm (W26mm x H54mm)
Weight: 235g

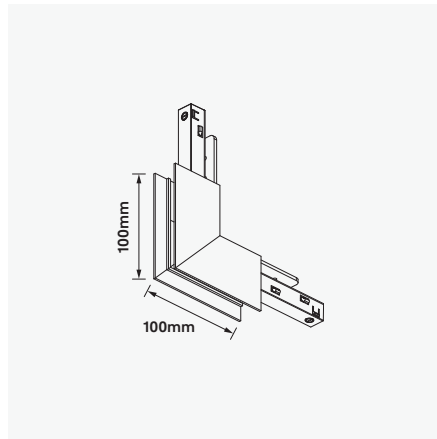

Surface / Suspended End Cap

Product No: TR-SM26-EC (PR)
Colour: Black
Size: W26.4mm x H54mm x D2mm
Weight: 10.4g

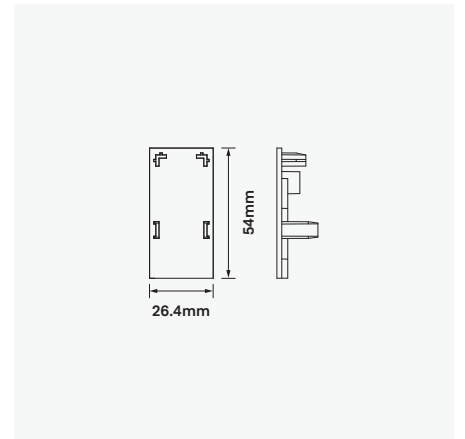

Suspension Kit-Adjustable

Product No: SUSP-KIT-3M-BLK | SUSP-KIT-3M-SIL
Colour: Black | Silver
Size: L3000mm
Weight: 60g

